



Quench Q5

Freestanding and Countertop Series with

- Appreciate refreshing filtered water at any time in any environment
- Choose robust, large capacity model that delivers a great user experience
- Feel protected from contamination with carbon filtration and UV light technology



water up 



Quench Q5

The Quench Q5 series levels up all break rooms from professional offices to schools and warehouses. This robust, large capacity water cooler features a generous dispenser to provide easy access to endless filtered cold and hot water. And the advanced filtration technologies, in-tank UV light, and antimicrobial surface protection offer distinct water quality assurance.



Built for a variety of environments

- Reverse osmosis or carbon filtration
- LED ultraviolet light to maintain water quality
- Rugged paddle dispensing and hot water safety feature
- Antimicrobial surface protection
- Taller ergonomic “no-bend” dispensing design (Freestanding model)
- Fits under most cabinets (Countertop model)

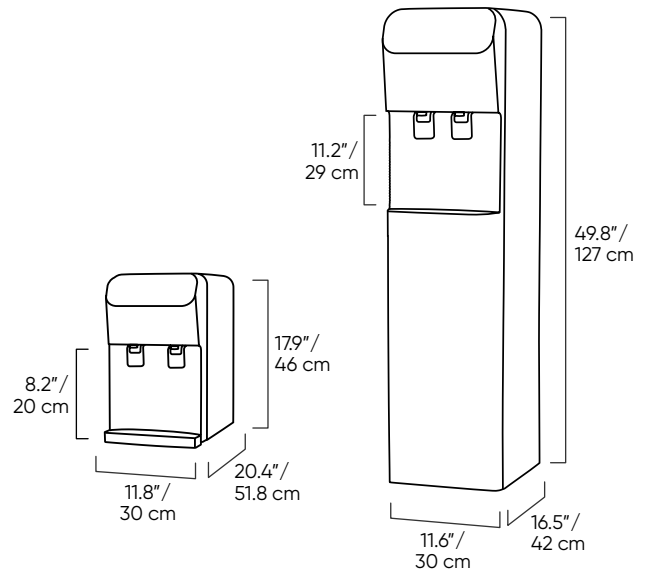

Specifications

Quench Q5 Freestanding

Dimensions	49.8" h x 11.6" w x 16.5" d / 127 cm h x 30 cm w x 42 cm d
Weight	60 lbs/28 kg
Cold Tank Capacity	1.6 gallons/6.1 liters
Hot Tank Capacity	0.7 gallons/2.7 liters
Dispensing Area Height	11.2" / 29 cm
Rated Voltage/Frequency	120V/60Hz
Power Consumption	1.6kWh/24 hours
Recommended Water Pressure	40 – 60 psi
Model Number	Q5FS

Quench Q5 Countertop

Dimensions	17.9" h x 11.8" w x 20.4" d / 46 cm h x 30 cm w x 51.8 cm d
Weight	49 lbs/23 kg
Cold Tank Capacity	1.0 gallons/3.8 liters
Hot Tank Capacity	0.4 gallons/1.4 liters
Dispensing Area Height	8.2" / 20 cm
Rated Voltage/Frequency	120V/60Hz
Power Consumption	1.1 kWh/24 hours
Recommended Water Pressure	40 – 60 psi
Model Number	Q5CT

The Quench Q5 is certified by IAPMO R&T according to NSF/ANSI 372 standards. For more information, please contact us.